

SOLAR WATER PUMP KIT MODEL: SIS-30HP



Model:	SIS -30HP
Pump Size:	6"
Capacity in HP:	30
PV Size in kW:	30
Water head range	50 - 159 meter
Water quantity range	20000 - 78000 liter per hour

Quantity	Description
120	Solar panels 250W polycrystalline
1	Water pump inverter 30 kW
1	Water pump 30HP 6", Model:SP060-12
1	Support structure for solar panels
300	1 meter DC cables 1x5.6mm R1000 2 core PV panel to pump inverter with thimble at ends
150	1 meter AC cable 3x5,6mm R1000 2 core inverter to main breaker with thimble at ends
1	String box for 8
7	MC4 Connector pair
1	50 Meter Steel wire for pump
1	1 installation tool kit

SYSTEM WARRANTY*:

Solar modules production:	25 years
Module support structure:	25 years
Inverters:	2 years
Pump:	2 years

Quality of Components:

Manufactured in EU.
All components in the kit are high quality with CE standard

Solar Water Pump 30 HP

These systems are modular and flexible and can be installed as per your space and requirement. You can ask for additional services as state-of-the-art designing, drawings, engineering and installation of your projects. The solar water pump kits are designed by experts from GRUNDFOS and SITECNO to meet the need of all kinds of water pumping.

Application areas

Designed for continuous as well as intermittent operation, the SITECNO solar system is especially suitable for water supply in remote locations such as:

- villages, schools, hospitals, single-family houses, etc.

farms and ranches

- watering of livestock
- irrigation of crops and green houses

game parks and game farms

- watering applications

conservation areas

- surface water pumping

ponds and lakes

- floating pump installations

Water pump range

- 30 HP

Output delivery pipe dia

- 6"

water head

- 50 to 159 meters
- 165 to 525 feet

Water delivery quantity

- 20000 to 78000 litres per hour
- 88 to 3432 gallon per minut

Sizing and selection made simple and easy:

All you need to determine is the following three parameters:

- geographical location
- required maximum head
- required water quantity per day

Polycrystalline Solar Module 250W

SITECNO Solar Photovoltaic Panels stand for quality, durability and most importantly, high performance. Our experience, capacity of research, continuing development and improvement have turned us into a company recognized in the sector by the high value offered to our clients.

Due to their engineered hollow section frame and its 4mm special textured glass with AR coating, SITECNO modules meet the maximum demands with regard to stability and corrosion resistance.

Thanks to their high performance SITECNO modules are prepared for changes in legislation. These panels will produce 5% more than any other of the same features.

The performance warranty is for 25 years, after 12 years, modules still produce a minimum 90% of their nominal performance. After 25 years module still produce a minimum 80% of their nominal performance.

Electrical Characteristics:

MODEL	SI-P60-250
Nominal Power (Pmax)	250W
Open Circuit Voltage (Voc)	37,5V
Short Circuit Current (Isc)	8,76A
Voltage at Nominal Power (Vmp)	30,3V
Current at Nominal Power (Imp)	8,24A
Module Efficiency (%)	15,20

Mechanical Characteristics:

Cell type	Polycrystalline 156x156mm
Number of cells	60 (6x10)
Module dimension	1660 x 990 x 50/40mm
Weight	20kg
Front cover	TSG low-iron tempered glass
Frame	Aluminium alloy
Junction box	IP65, 3diodes
Cable length	1200mm (+) , 800mm(-)
Connector	PV-JM601

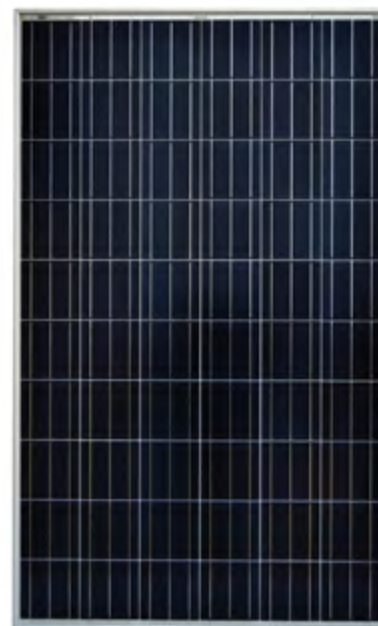

Temperature Coefficients:

Nominal Operating Cell Temperature (NOCT)	25°C ±2°C
Temperature Coefficients of Pmax	-0.43% / °K
Temperature Coefficients of Voc	-0.31% / °K
Temperature Coefficients of Isc	0.04% / °K
Operating Temperature	-40 °C to +85 °C
Maximum System Voltage	1000V DC
Reverse current load	15A

Solar Water Pump Inverter 30 kW

Application options

A wide range of integrated water application options can be fitted into the drive:

- Real time clock with battery back-up
- General purpose I/O option:
 - 3 digital inputs, 2 digital outputs, 1 analog current output, 2 analog voltage inputs
- Relay option/cascade controller option: 3 relay outputs
- External 24 VDC supply option: 24 VDC external supply can be connected to supply control and option cards
- Brake chopper option:
 - Connected to an external brake resistor, the brake chopper limits the load on the intermediate circuit in case the motor acts as generator.
- Extended cascade control of up to a total of 6 pumps
- Advanced cascade control of up to a total of 8 pumps
- Analogue sensor input option with up to 3 temperature sensor inputs

Power options

Danfoss Drives offers a wide range of external power options for use together with our drive in critical networks or applications:

- Advanced Harmonic Filters: for applications where reducing harmonic distortion is critical
- dU/dt filters: For providing motor isolation protection
- Sine filters (LC filters): For noiseless motor and low dU/dt

Complementary products

- A broad range of soft starters
- Decentralize drive solutions

PC software

- MCT 10
 - ideal for commissioning and servicing the drive including guided programming of cascade controller, real time clock, smart logic controller and preventive maintenance.
 - comprehensive energy analysis tool, shows the drive payback time

Specifications

Mains supply (L1, L2, L3)

Supply voltage : 380 – 480 V $\pm 10\%$
Supply frequency: 50/60 Hz

Output data (U, V, W)

Output voltage : 0 – 100% of supply voltage
Switching on output Unlimited
Ramp times : 1 – 3600 sec
Closed loop : 0 – 132 Hz

Digital inputs

Programmable digital inputs: 6
Logic : PNP or NPN
Voltage level : 0–24 V
Thermistor inputs : 1

Analog input

Analog inputs : 2
Modes Voltage or current
Voltage level : 0 – 10 V (scalable)
Current level : 0/4 – 20 mA (scalable)

Pulse inputs

Programmable pulse inputs : 2
Voltage level : 0-24 VDC (PNP positive logic)
Pulse input accuracy : (0.1 – 110 kHz)
Utilize some of the digital inputs

Analog output

Programmable analog outputs : 1
Current range at analog output : 0/4 – 20 mA
Max. load : (24 V) 130 mA

Temperature

Ambient temperature : up to 55° C



Solar Water Pump 30 HP

Pump drive

SP pumps are primarily used for pumping of raw water from the underground. The pumps are installed in boreholes or wells, submerged below the water level. For industrial purposes the pump can be placed in e.g. a tank.

Features and benefits

A wide pump range **GRUNDFOS** offers energy-efficient submersible pumps ranging from 1 to 280 m³/h. The pump range consists of many pump sizes, and each pump size is available with an optional number of stages to match any duty point.

High pump efficiency

Often pump efficiency is a neglected factor compared to the price. However, the observant user will notice that price variations are without importance to water supply economics compared to the importance of pump and motor efficiencies. The SP A and SP pumps are suitable for the following applications:

- raw-water supply
- irrigation
- groundwater lowering
- pressure boosting
- fountain applications
- mining applications
- off-shore applications.

Material specification (SP 60 - SP 95 - SP 125)

Pos.	Component	Material	Standard	N-version	R-version
			EN/AISI		
1	Valve casing	Stainless steel	1.4301/304	1.4401/316	1.4539/904L
2	Valve cup	Stainless steel	1.4301/304	1.4401/316	1.4539/904L
3	Valve seat	NBR-FKM	NBR-FKM	NBR-FKM	NBR-FKM
7	Neck ring	NBR-FKM	NBR-FKM	NBR-FKM	NBR-FKM
8	Bearing	NBR-FKM	NBR-FKM	NBR-FKM	NBR-FKM
		LSR	LSR	LSR	LSR
8a	Washer for stop ring	Carbon/graphite	HY22	in PTFE mass	
9	Chamber	Stainless steel	1.4301/304	1.4401/316	1.4539/904L
13	Impeller	Stainless steel	1.4301/304	1.4401/316	1.4539/904L
14	Suction Cast interconnector	stainless steel	1.4308	1.4408	1.4517
15	Strainer	Stainless steel	1.4301/304	1.4401/316	1.4539/904L
16	Shaft complete	Stainless steel	1.4057/431	1.4460/329	1.4462/904L
17	Strap	Stainless steel	1.4301/304	1.4401/316	1.4539/904L
18	Cable guard	Stainless steel	1.4301/304	1.4401/316	1.4539/904L

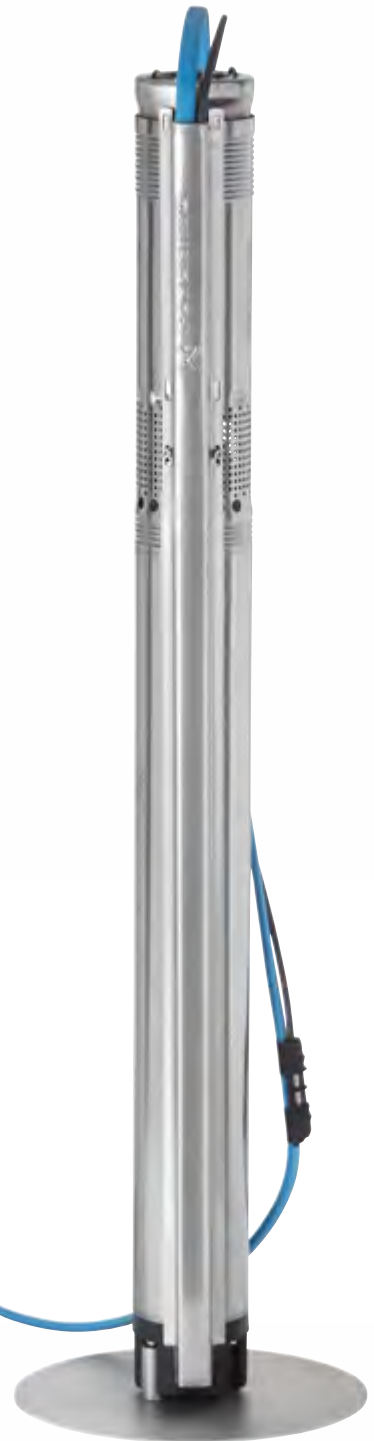

WATER OUTPUT DATA

Water Quantity	Litre/Hour	20000	30000	40000	50000	70000	780000
Pump Model	GPM	88	132	176	220	308	3432
	kW/HP	Meter/Feet	Meter/Feet	Meter/Feet	Meter/Feet	Meter/Feet	Meter/Feet
		159/525	143/472	126/416	110/363	72/238	50/165

ACCESSORIES

Design and manufacture

Type

Technical feature

Weight

Loads

Test certificate

SITECNO Spain

Modular type

Aluminium

25 years warranty

Tamper proof nut bolt

100% recyclable material

A2 Stainless steel bolts

2,49kg/m

wind, snow

CE Certifies

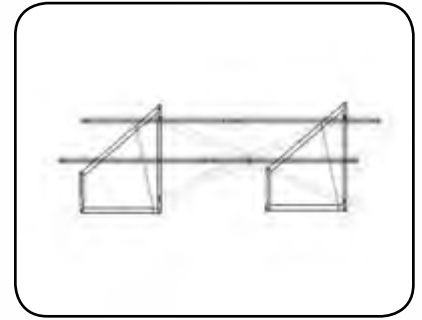

Support structure

Cable:

Manufacture

· Model:

· Rated Voltage:

· Rating Current:

· Cable Size:

· Proof Voltage:

· Protection Class:

· Temperature Range:

· Flame class:

Top Cable Spain

SI-MC4-F

TUV 1500V DC / UL 600V DC

20-30A

2.5-4.0-6.0, 10-12-14AWG

TUV 1500V AC, 1 min

Class II

-40 to 85°C

UL94-V0



Cable

Connector:

Flexible conductor,

Maximum service temperature:

Estimated lifetime

UV Resistant UV Resistant

Grease & mineral oils resistance:

Grease & mineral oils resistance:

class 5

120°C

30 years.

excellent

excellent



Cable connector MC4

Wire roop:

Material: Stainless steel



Wire roop

You get it all

- FREE reliable water supply
- COST FREE-efficient pumping
- Complete plug-and-pump system
- Wide voltage range
- AC and DC voltage handling easy installation
- Virtually no maintenance
- Numerous expansion possibilities

Single line diagram



NON STOP FREE WATER WITH SOLAR ENERGY



Authorized distributor:

SITECNO GROUP
C/ Can balmes 1, Zona industrial,
Santa. M^a. de Palautordera,
08460 Barcelona, Spain.
Tel: +34 938482544
Fax: +34 938480439
info@sitecnosolar.eu
www@sitecnosolar.eu

